

An Article From:

# SCIENCE & MEDICINE

JULY/AUGUST 1999

•

VOLUME 6, NUMBER 4

COPYRIGHT © 1999 by SCIENCE & MEDICINE, INC. ALL RIGHTS RESERVED.

# Acupuncture Meridians

by Hiroshi Motoyama

The theories of *prana* (vital energy or *chi*) and *nadis* (vital energy channels or *chi mai*), which were clinically and empirically understood in the medical and yogic traditions of India, were brought to China about 2700 years ago. Acupuncture medicine was then gradually developed by systematizing the 12 regular and 8 extra meridians, based on clinical experience, and treatment effects have been conferred on the people there.

The meridian theory in China was grounded on both the metaphysical Yin-Yang and Five-Element philosophies and on clinical experience. Neither an anatomical location nor a physiological function of a meridian has ever been evidenced from the Western medical viewpoint. Evidence for the existence and function of the meridians has been obtained in more than 25 years of research using Western medical and biophysical methods and is the subject of this article.

Acupuncture medicine considers that the body has three divisions. The upper part corresponds to the respiratory and circulatory systems, the middle part to the digestive system, and the lower part to the urogenital system. The triple heater meridian distributes energy to each part. Because Western medicine recognizes no equivalent to the triple heater meridian, it became my choice as the subject for investigation. An experiment was designed to discover evidence for this meridian using electrophysiological methods.

## HIROSHI MOTOYAMA

holds Ph.D.'s in philosophy and psychophysiology from Tokyo University of Literature and Science. He founded the Motoyama Institute for Life Physics in Tokyo (1990) and the California Institute for Human Science (1992). Dr. Motoyama is the author of more than 50 books and numerous monographs, all devoted to various aspects of energy, consciousness, and parapsychology.

This series is edited by John D. Young and explains the basis for alternative and complimentary therapies.

Recording electrodes were placed on the right palm and on seven acupuncture points closely connected with the triple heater meridian. A rectangular wave was applied at regular intervals, and then a stimulus was applied to the well point of the triple heater meridian (TH1, located near the exterior nailbed corner of the ring finger). The subject felt pain, and negative potentials were recorded at all measurement points within a few milliseconds. An identical response was recorded at the right palm, indicating that the potentials represented sympathetic nerve responses accompanied by pain.

The voltage was then reduced so that neither the sensation of pain nor the stimulation could be felt, and a stimulus was applied to TH1. Two to three seconds after stimulation, a positive potential was recorded only at two points of the triple heater meridian: the associated point UB22, which is located 3.5 cm lateral to the cartilage between the first and second lumbar vertebrae, and the alarm point CV5, about 3 to 5 cm below the navel.

The associated and alarm points represent viscerocutaneous reflex points through which the condition of the internal organs is reflected as cutaneous symptoms. The associated point can also be said to be the gate through which *chi* or bioenergy flows into an internal organ and the alarm point the location of an accumulation of energy coming from an internal organ. Both points can be used diagnostically to reflect the health of the corresponding organ.

Comparing the sympathetic nervous response accompanied by pain and the painless response, it is seen that (1) negative potential changes were seen at all measurement points at the time of nervous response, whereas in the painless response, reactions were seen only at triple heater meridian points distant from TH1 and having no relation in terms of either spinal or sympathetic nerve distribution; (2) the nervous response was recorded as a negative potential change and the painless response as a positive potential

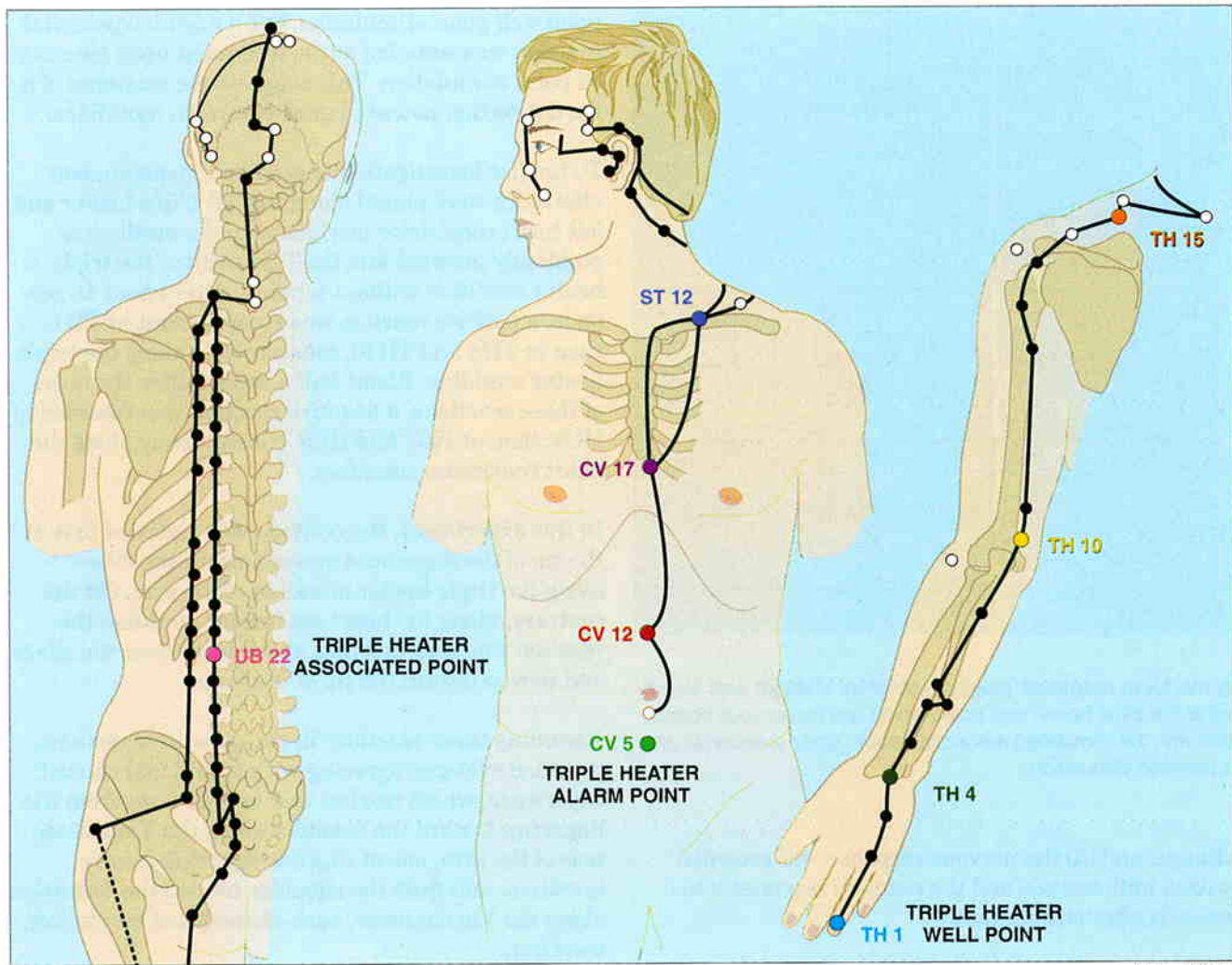

Recording electrodes were placed on seven points closely associated with the triple heater meridian. Sympathetic nervous responses (negative potentials) were recorded at all measurement points within a few milliseconds upon a painful (20-volt)

stimulus. Meridian responses (positive potential changes) were recorded at the triple heater associated and alarm points, which have no nervous connection with the stimulated well point, 2 to 3 seconds after a painless (15-volt) stimulus.

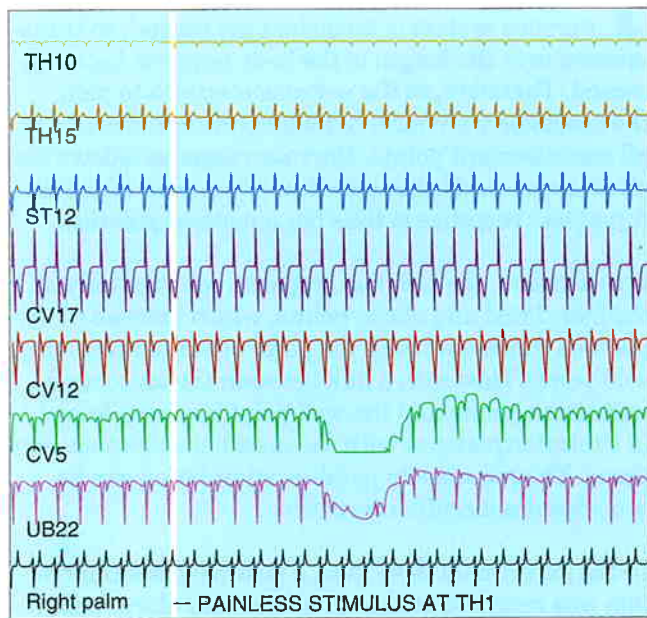
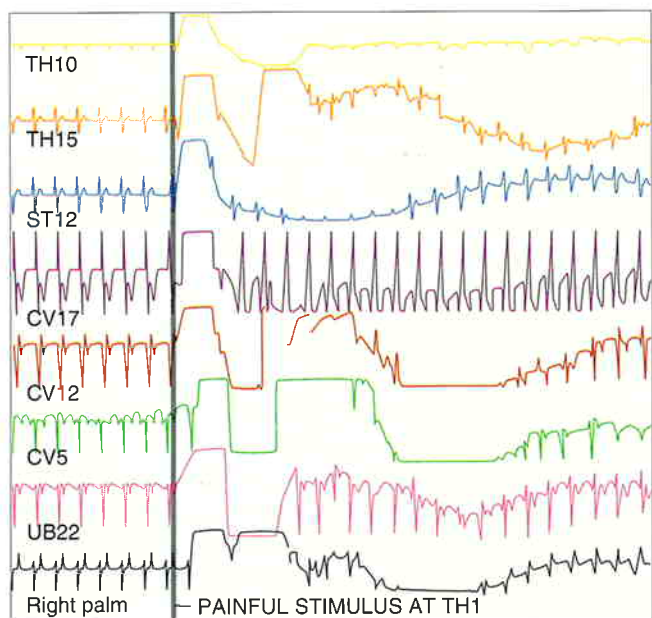

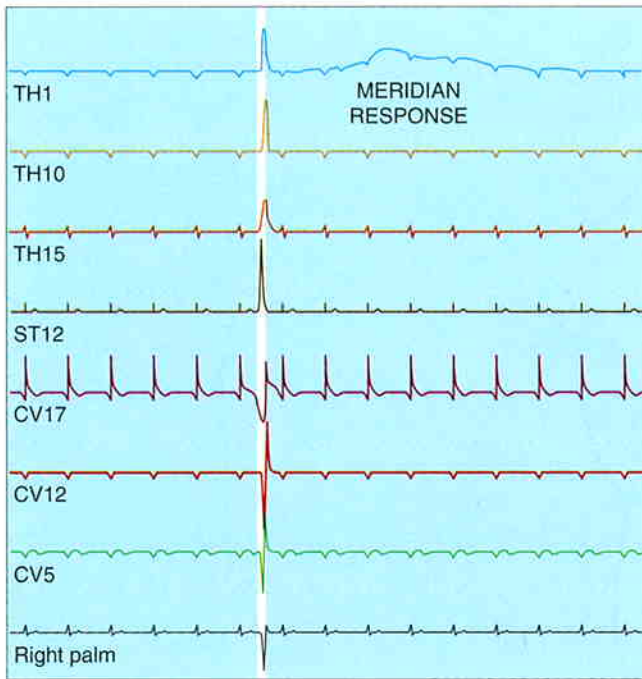

**A meridian response** (negative potential change) was recorded at the triple heater well point, which has no nervous connection with the stimulated associated point, about 2 seconds after a painless stimulation.

change; and (3) the nervous response was recorded within milliseconds and the painless response 2 to 3 seconds after stimulation.

Also, when a painless rectangular wave pulse stimulus was applied to the left associated point of the triple heater meridian (UB22), a negative potential change was recorded about 2 seconds later at the triple heater well point (TH1), but not at any other point.

**T**he averaged signal transmission velocity of the nervous system is 60 meters per second, so transmission over the length of the body requires  $\frac{1}{30}$  to  $\frac{1}{40}$  second. Therefore, in the nervous response to pain, the reactions were recorded almost simultaneously at all measurement points. Nervous response follows the all or none law: it does not occur when pain is not felt. A painless response is thus not a nervous reaction.

Furthermore, the painless response occurred only at the associated and alarm points, which have no direct nervous connection with the point of stimulation (the well point). However, a link between the associated and alarm points and the well point has been known in clinical experience with the meridians since ancient times. The response to painless stimulation can be considered a meridian response.

In the experiment described, a positive potential reaction was recorded at the associated and alarm points

upon well point stimulation, but a negative potential reaction was recorded at the well point upon associated point stimulation. This suggests the existence of a fixed-direction potential gradient in the meridians.

To further investigate this gradient, measurement electrodes were placed along the left triple heater and left heart constrictor meridians, and a needle was painlessly inserted into the TH4 point of the triple heater meridian without tapping. After about 16 seconds, a positive reaction was recorded first at TH1, then at TH4 and TH10, consecutively along the triple heater meridian. About half a second after the onset of these reactions, a negative reaction was recorded at HC3, then at HC7 and HC9, consecutively along the heart constrictor meridian.

In this experiment, the reaction was recorded first at the tip of the finger and moved toward the elbow along the triple heater meridian of the arm. On the contrary, along the heart constrictor meridian the reaction was recorded first at the point near the elbow and moved toward the tip of the finger.

Recording these reactions in the opposite directions provided evidence agreeing with traditional clinical experience, which teaches that energy flows from the fingertips toward the shoulder along the Yang channels of the arm, one of which is the triple heater meridian, and from the shoulder toward the fingertips along the Yin channels, such as the heart constrictor meridian.

The reactions recorded in the Yang meridian were positive, but those in the Yin meridian were negative, which is further evidence that the direction of energy flow is opposite in Yin and Yang channels.

From these experimental results, three conclusions were drawn. (1) The nervous system and the meridian system are different information transmission systems in the body. (2) In the meridian system, there are Yin and Yang channels in which electrical energy flows in opposite directions, coinciding with clinical experience from ancient times. (3) There is a close connection between the well point and the associated and alarm points through the meridian system but not through the nervous system.

**W**hen two insulated needle electrodes, each having an exposed metal tip 5 to 6  $\mu\text{m}$  in length, were inserted so that the exposed tips penetrated a meridian in the dermis, a potential gradient of 150 to 300 mV was measured between the electrodes. It is considered that the gradient is generated by the negative potential of mucopolysaccharides such as hyaluronic acid in dermal connective tissue and the positive potential of cations.



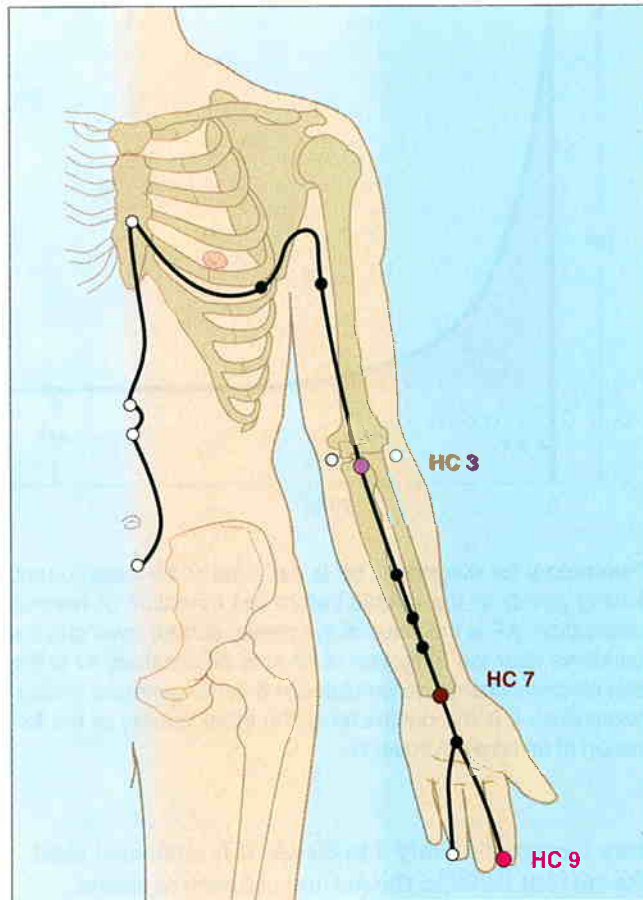
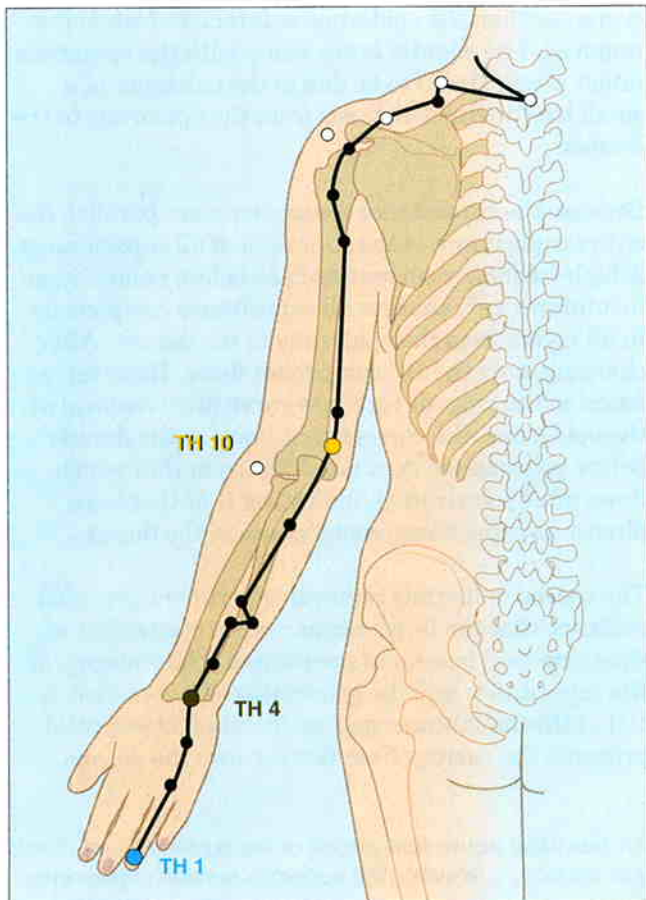

ANNE ERICKSON

An apparatus has been devised to measure the flow of this energy between recording electrodes placed on the well points and grounded electrodes on the wrists. A pulse generator applies a rectangular 3-volt DC wave pulse of 1024  $\mu\text{sec}$  duration, and the current is converted into digital signals. The system is known as the "Apparatus for measuring the functioning of the Meridians and their associated Internal organs," or AMI.

Initially the flow is an alternating current with a frequency of more than 1 MHz. After about 500  $\mu\text{sec}$ , it becomes a steady-state direct current. These two currents are referred to as "before polarization" or BP and "after polarization" or AP. In other words, the skin can be viewed as a large capacitor, which generates a potential of reverse polarity when challenged with an electrical potential. The currents that can be measured before and after the formation of the reverse polarization are the BP and AP. Other parameters measured are the total charge accumulated in order to generate reverse polarization and the time required to complete the reverse polarization process.

Before polarization, current flows at about 2 mA and is therefore assumed to flow in tissue, where resistance is about 1.5 k $\Omega$ . In the epidermis, resistance is 100 k $\Omega$  to 1 M $\Omega$ , so applying 3 volts DC would pro-

**Reactions of different polarity** were recorded along the left triple heater and left heart constrictor meridians after a needle was painlessly inserted into the TH4 point without tapping. About 16 seconds after the stimulation, a positive reaction was seen first at TH1, then at TH4 and TH10 consecutively along the triple heater meridian. About half a second after the onset of the triple heater reactions, a negative response was recorded at HC3, then at HC7 and HC9, consecutively along the heart constrictor meridian.

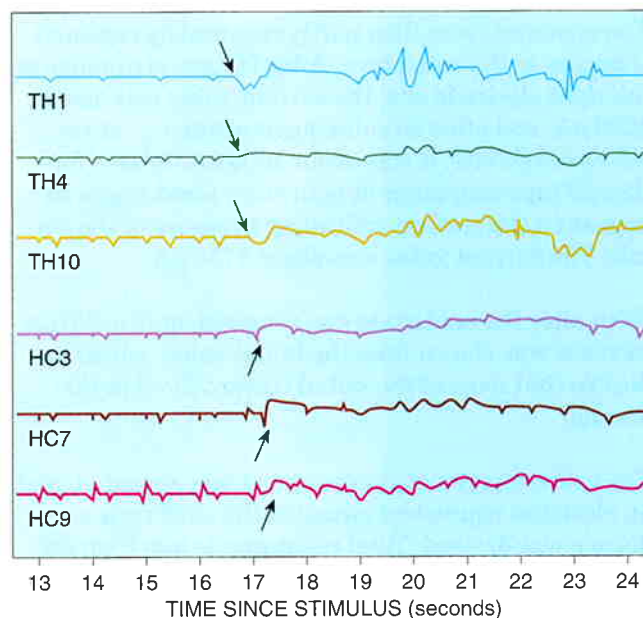

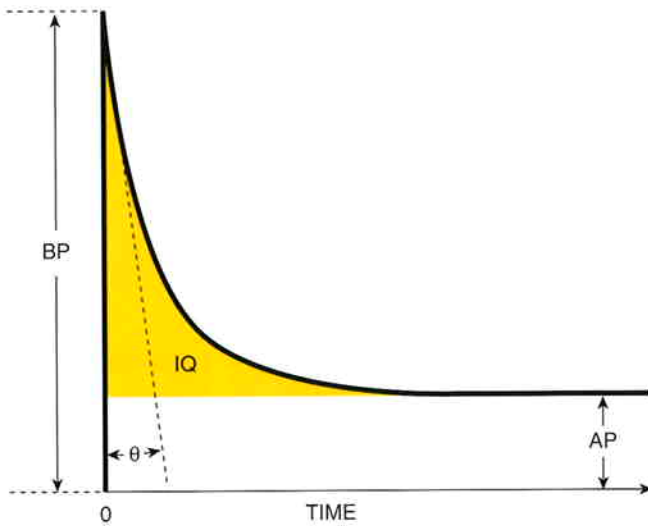

**Parameters for diagnosis.** BP is the value of the initial current, flowing mainly in the dermis before the formation of reverse polarization. AP is the value of the steady current flowing in the epidermis after the formation of reverse polarization. IQ is the total electrical charge accumulated in order to generate reverse polarization.  $\theta$  is the parameter of the initial velocity of the formation of reverse polarization.

duce a current of only 3 to 30  $\mu\text{A}$ . It is surmised that the current flows in the dermal connective tissue, where water content is high and there are few cellular components.

To test this assumption, an epidermis removal experiment was performed. Electrodes were placed on the left and right LV3 points on the tops of the feet (the source points of the liver meridian), and a 3-volt DC pulse potential was applied between the two electrodes. With the epidermis intact at both points, a current value of approximately 1330  $\mu\text{A}$  was recorded.

The epidermis was then partly removed by repeated stripping with Scotch tape. After 20 tape strippings at the right electrode site, the current value was about 1350  $\mu\text{A}$ , and after 20 subsequent strippings at the left electrode site, it was about 1600  $\mu\text{A}$ . After a further 20 tape strippings at both sites, blood began to appear on the surface, indicating exposure of the dermis. The current value was about 1750  $\mu\text{A}$ .

Even after the epidermis was removed, only a 420  $\mu\text{A}$  increase was shown from the initial value, which indicates that most of the initial current flows in the dermis.

The epidermis removal experiment was repeated, and an electrical equivalent circuit of the epidermis and dermis was devised. Total resistance is less than epidermal resistance, even if epidermal resistance is 1  $\text{M}\Omega$ . There is therefore only a small difference between the

currents when the epidermis is intact and when it is removed. The slightly lower value with the epidermis intact is considered to be due to the existence of a small lengthwise resistance from the epidermis to the dermis.

Because the capacitance components are parallel, the entire capacitance is the sum total of all capacitances. A high-frequency current such as before polarization instantaneously charges all capacitance components in all layers from the epidermis to the dermis. After charging, only the DC component flows. However, as found in the current response curve after removal of the epidermis, the current that flows in the dermis before polarization does not differ from that which flows after polarization, indicating that there are almost no capacitance components in the dermis.

The second epidermis removal experiment provided evidence that the largest capacitance component is the epidermal basement membrane. The charging of the capacitance and the generation of reverse potential at this membrane against the applied potential prevents the current from flowing into the dermis.

**An electrical equivalent circuit** of the epidermis and dermis was devised by repeating the epidermis removal experiments.

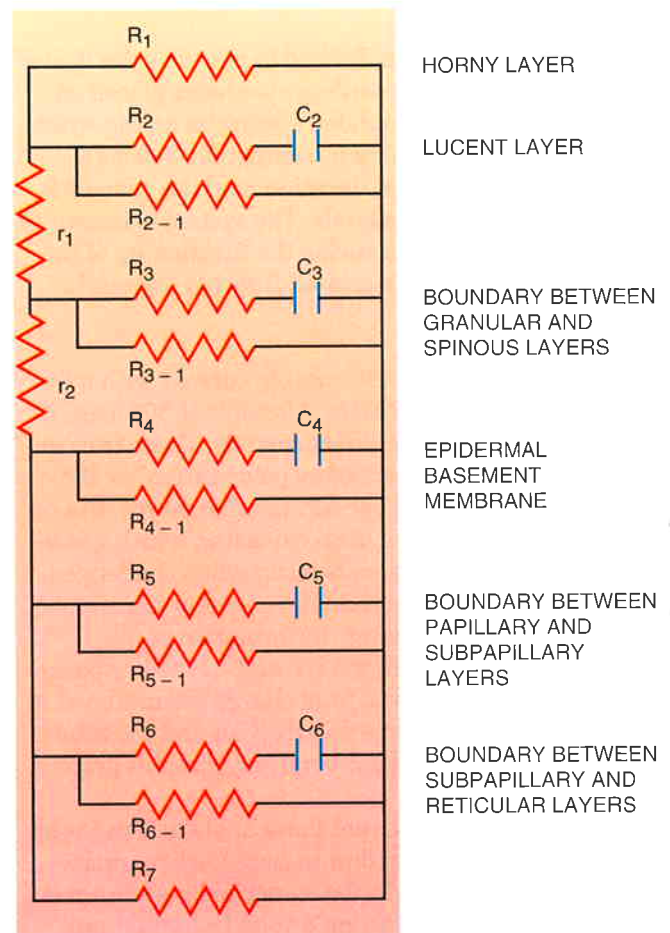

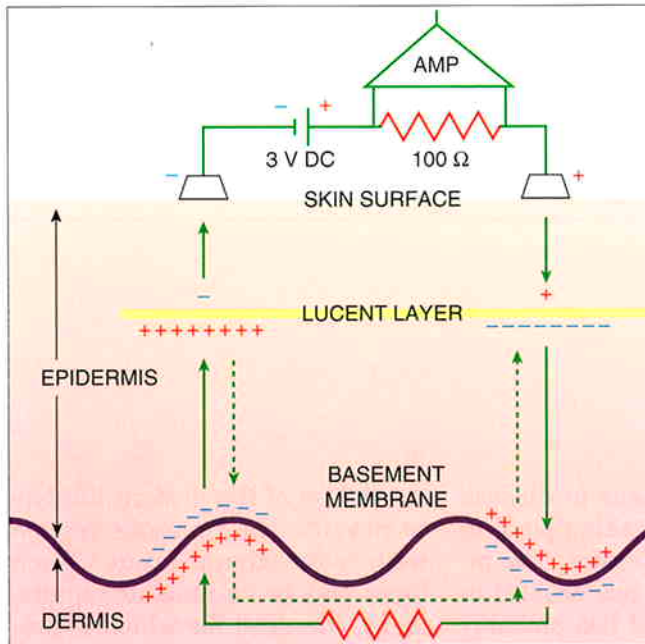

If current is allowed to flow from the positive side of a source back to the negative side through electrodes on the skin surface, the lucent layer and basement membrane act as capacitors. Charging these capacitors generates a potential gradient that counteracts the current flow.

After formation of reverse polarization, the direct current flows only in the epidermis.

According to traditional meridian theory, the 12 meridians are composed of six Yin-Yang pairs. In each pair, the before polarization value of the Yin meridian is larger than that of its Yang partner. This relationship is not always maintained in other parameters, such as after polarization, indicating that the before polarization current alone is the parameter of meridian function.

As has been mentioned, there is a close connection between the well, associated, and alarm points of a particular meridian. It is well known in clinical acupuncture that treatments on the associated and alarm points are effective for malfunction and diseases of the organ corresponding to the meridian. There is evidence that needle treatments on the origin point of the meridian diagnosed as most excessive and on the associated and alarm points of the meridian diagnosed as most deficient are also effective.

A test of treatment effects was performed for further substantiation. Prior to needle insertion, current flow was measured with the apparatus described, the electrodes being placed on the well points. Needles were then inserted on the origin point of the meridian diagnosed as most excessive and on the associated and alarm points of the meridian diagnosed as most defi-

cient, and current data was taken again. There was a significant difference in before polarization values but not in other parameters.

Finally, an experiment showed that the after polarization current value is the parameter of sympathetic nervous function. The recording electrode was placed at LU11, the well point of the lung meridian, with the pair of grounded electrodes on the left and right TH5 points. Current values before and after polarization were continuously measured at LU11.

When a burning incense stick was brought close to the left LI4, the subject felt the sensation of heat, and a reaction was recorded in the after polarization current value but not in the before polarization value. Next, when moxa cones were burned one after another on the left LI4, the reaction was again recorded each time in the after polarization value. For the before polarization value, however, instead of a reaction to each stimulation, a gradual increase was recorded.

This experiment also substantiates that the after polarization current is a short-term nervous response, that the before polarization current is a gradual response, and that the two are distinct responses.

The conclusions from these experiments are as follows. (1) The dermis, or more precisely the dermal connective tissue, where the before polarization current flows, is the physical location of the meridians. (2) The phase of the potential reaction differs between sympathetic nervous response and meridian response, and there is a time-related difference as well. (3) The meridian system and the nervous system have distinct distributions.

In practice, the AMI is an effective tool in screening patients for chronic diseases such as cancer and Parkinson's disease. The BP value of each individual meridian accurately reflects the functional condition of the corresponding organ. The AMI may eventually displace expensive, painful, and time-consuming tests for large population screening.

#### FOR MORE INFORMATION

Hiroshi Motoyama, Warren T. Smith, and Toshiaki Harada: Pre-polarization resistance of the skin as determined by the single square voltage pulse method. *Psychophysiology* 21:541-550, September 1984.

Hiroshi Motoyama: Measurements of Ki Energy Diagnoses and Treatments. Tokyo, Human Sciences Press, 1997.

Hiroshi Motoyama: Comparisons of Diagnostic Methods in Western and Eastern Medicine. Tokyo, Human Science Press, 1999.

Details on research with the AMI are available at CIHS (graduate school and research center), 701 Garden View Court, Encinitas CA 92024; phone 760-634-1771, fax 760-634-1772, E-mail cihs@adnc.com, Web site <http://www.cihs.edu>.